

5' Hot Tubs / Option Index

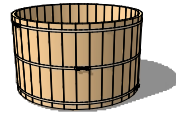

Tub Only

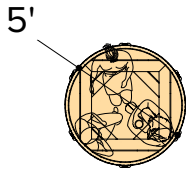
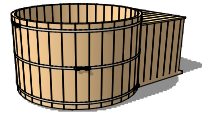

Equipment Box

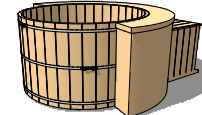

Skirting Kit

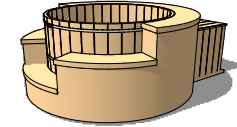

Multi Skirting Kit

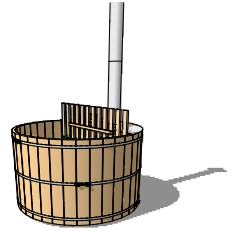

Wood Fired



Tub Height



2	3	4	5	6
7	8	9	10	11
12	13	14	15	16
17				

Rectangle Concrete Pad	Circular Concrete Pad
18	19

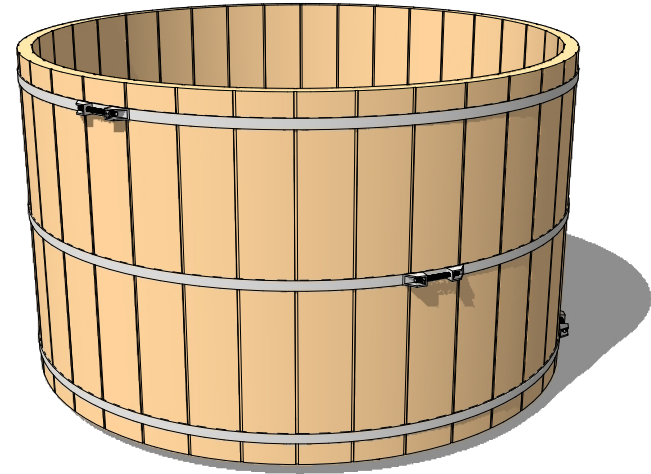
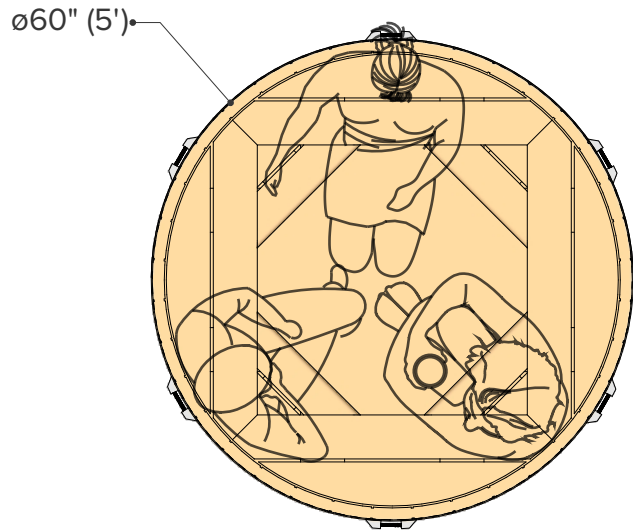

Occupancy	Water Capacity <small>(6" gap between top of tub to water level)</small>	Water Weight <small>(6" gap between top of tub to water level) (water weight calculated at 50°F / 10.0°C)</small>
Typical: 3	1086 Litres	1086 Kilograms
Max: 4	287 Gallons	2394 Pounds

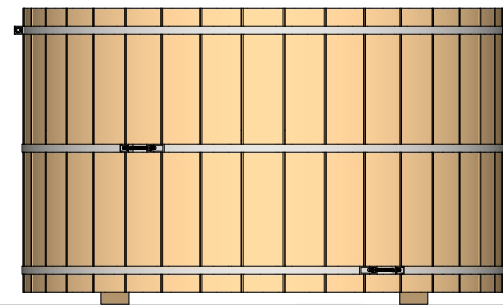
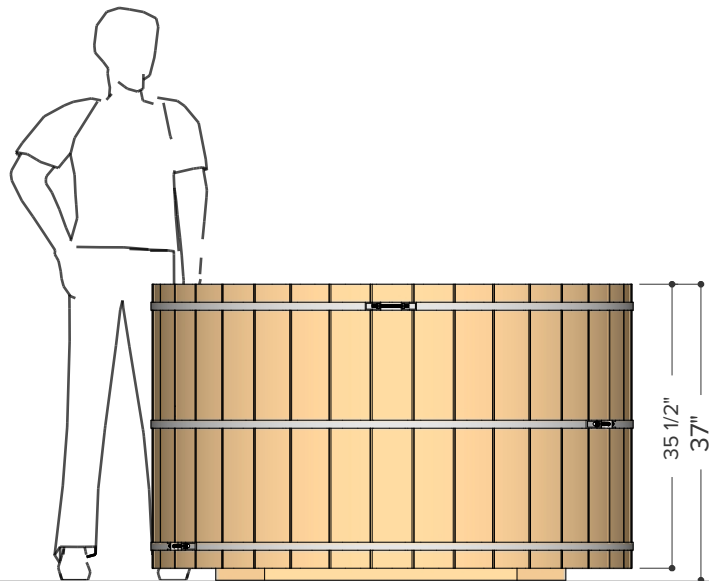

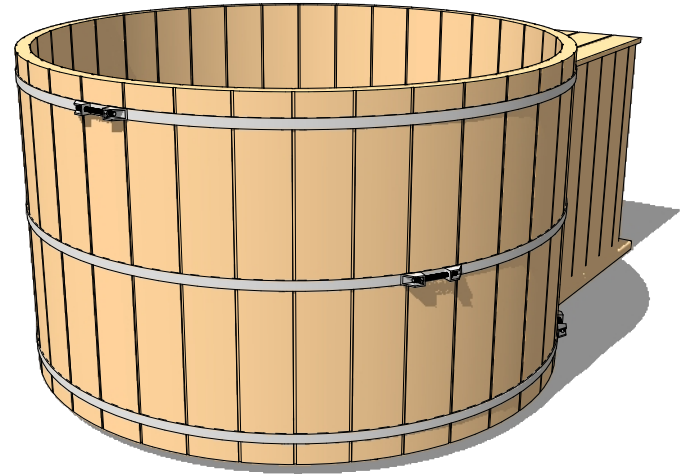
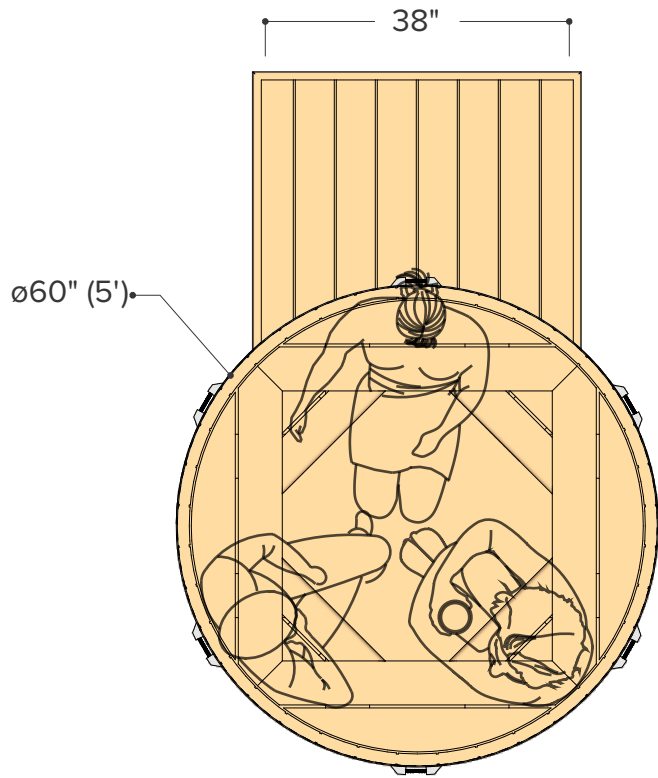

Occupancy	Water Capacity <small>(6" gap between top of tub to water level)</small>	Water Weight <small>(6" gap between top of tub to water level) (water weight calculated at 50°F / 10.0°C)</small>
Typical: 3	1086 Litres	1086 Kilograms
Max: 4	287 Gallons	2394 Pounds

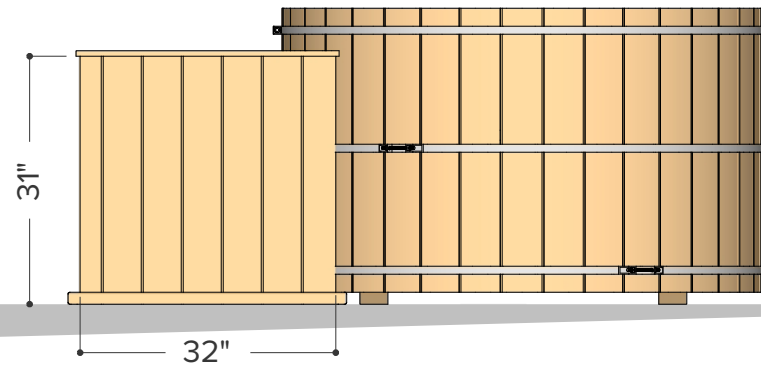
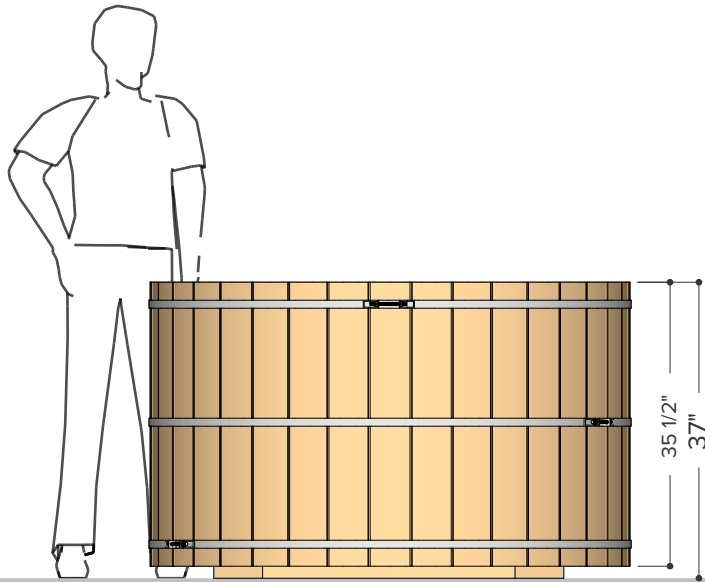

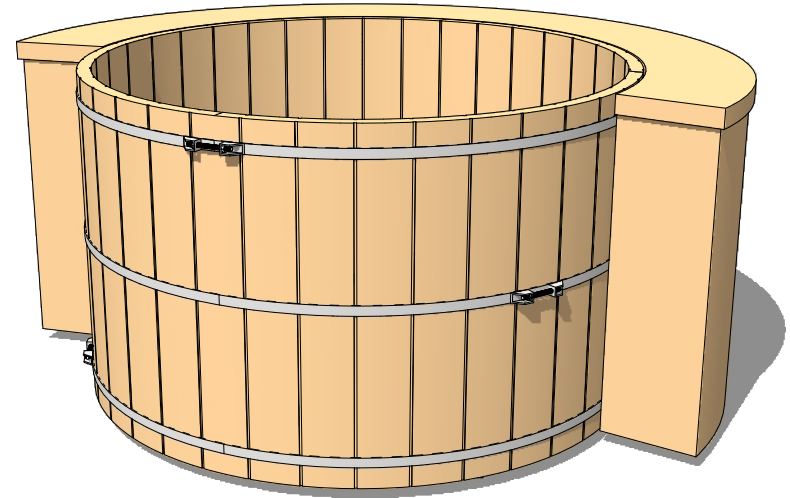
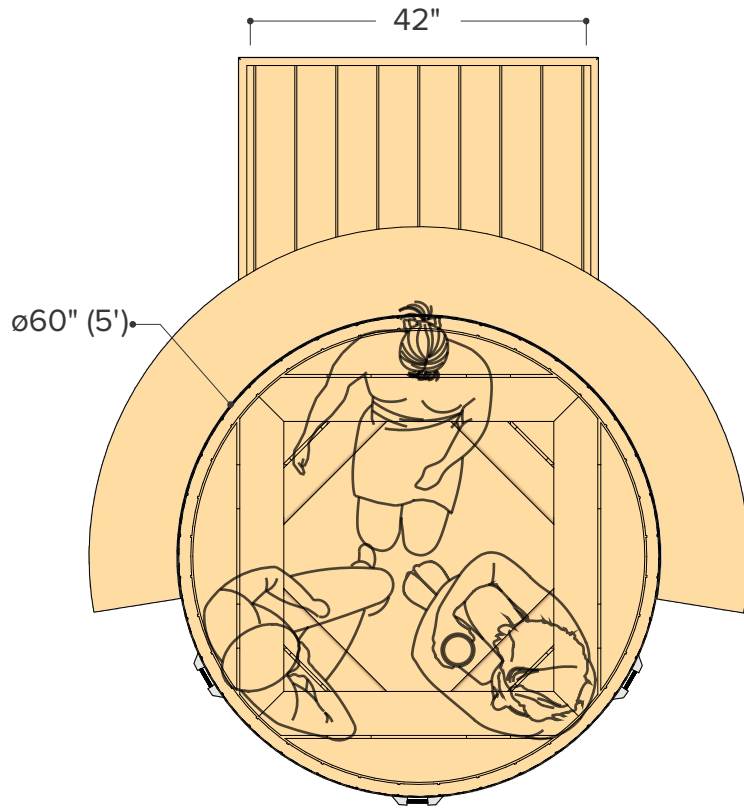

Occupancy	Water Capacity <small>(6" gap between top of tub to water level)</small>	Water Weight <small>(6" gap between top of tub to water level) (water weight calculated at 50°F / 10.0°C)</small>
Typical: 3	1086 Litres	1086 Kilograms
Max: 4	287 Gallons	2394 Pounds

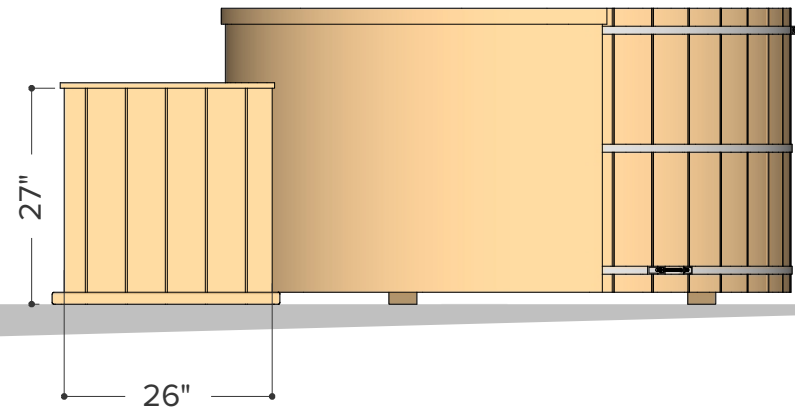
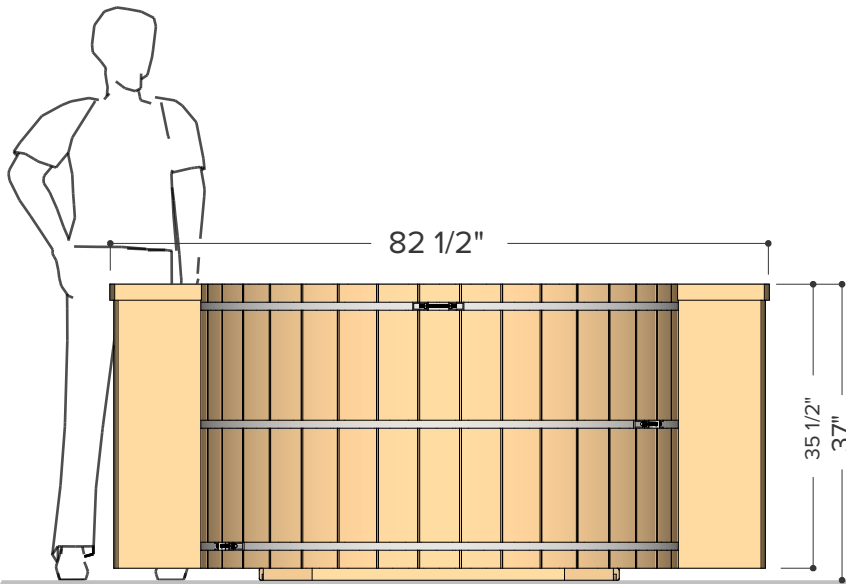

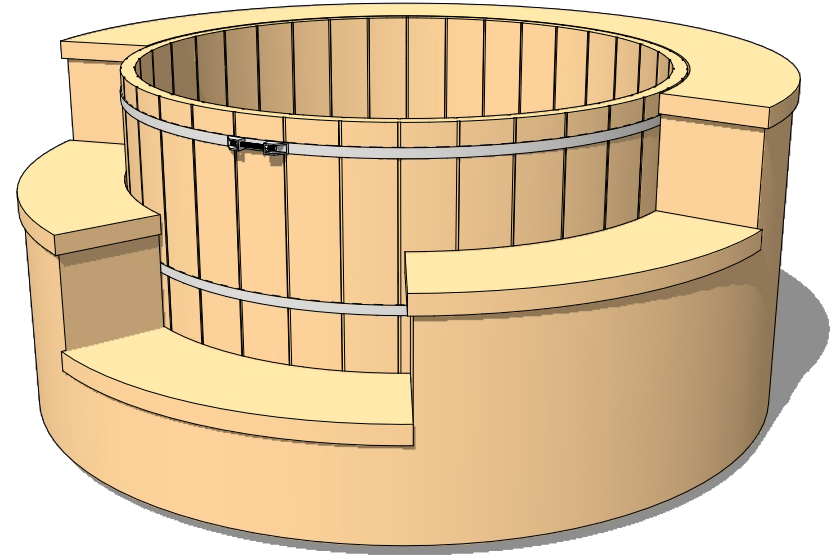
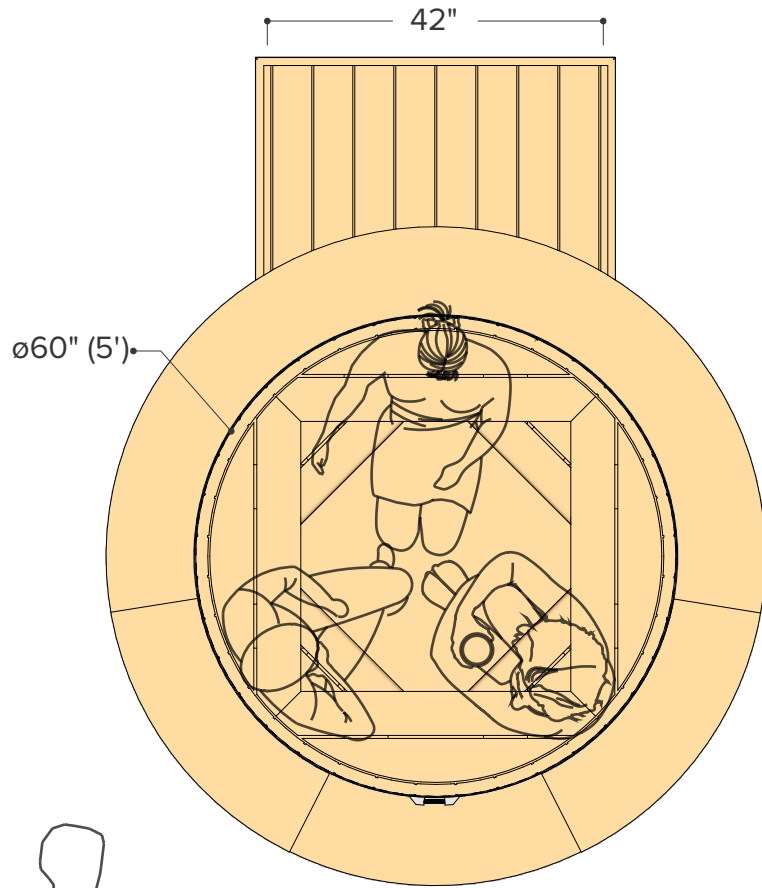

Occupancy	Water Capacity <small>(6" gap between top of tub to water level)</small>	Water Weight <small>(6" gap between top of tub to water level) (water weight calculated at 50°F / 10.0°C)</small>
Typical: 3	1086 Litres	1086 Kilograms
Max: 4	287 Gallons	2394 Pounds

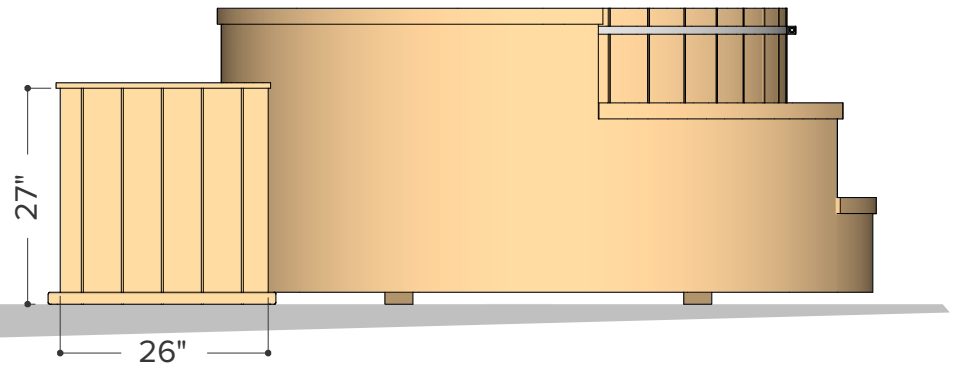
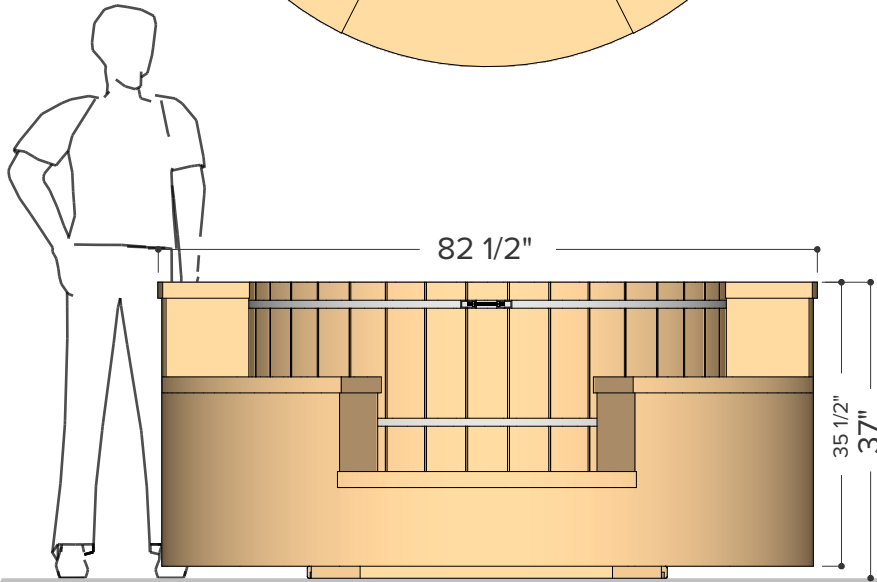

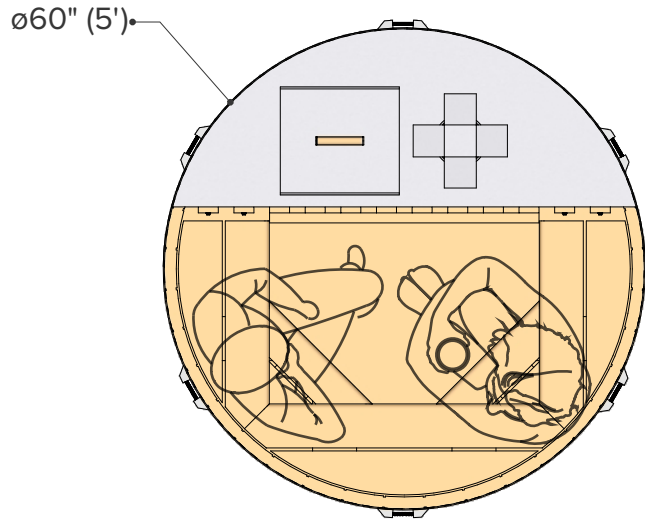

Occupancy	Water Capacity <small>(6" gap between top of tub to water level)</small>	Water Weight <small>(6" gap between top of tub to water level) (water weight calculated at 50°F / 10.0°C)</small>
Typical: 2	1086 Litres	1086 Kilograms
Max: 3	287 Gallons	2394 Pounds

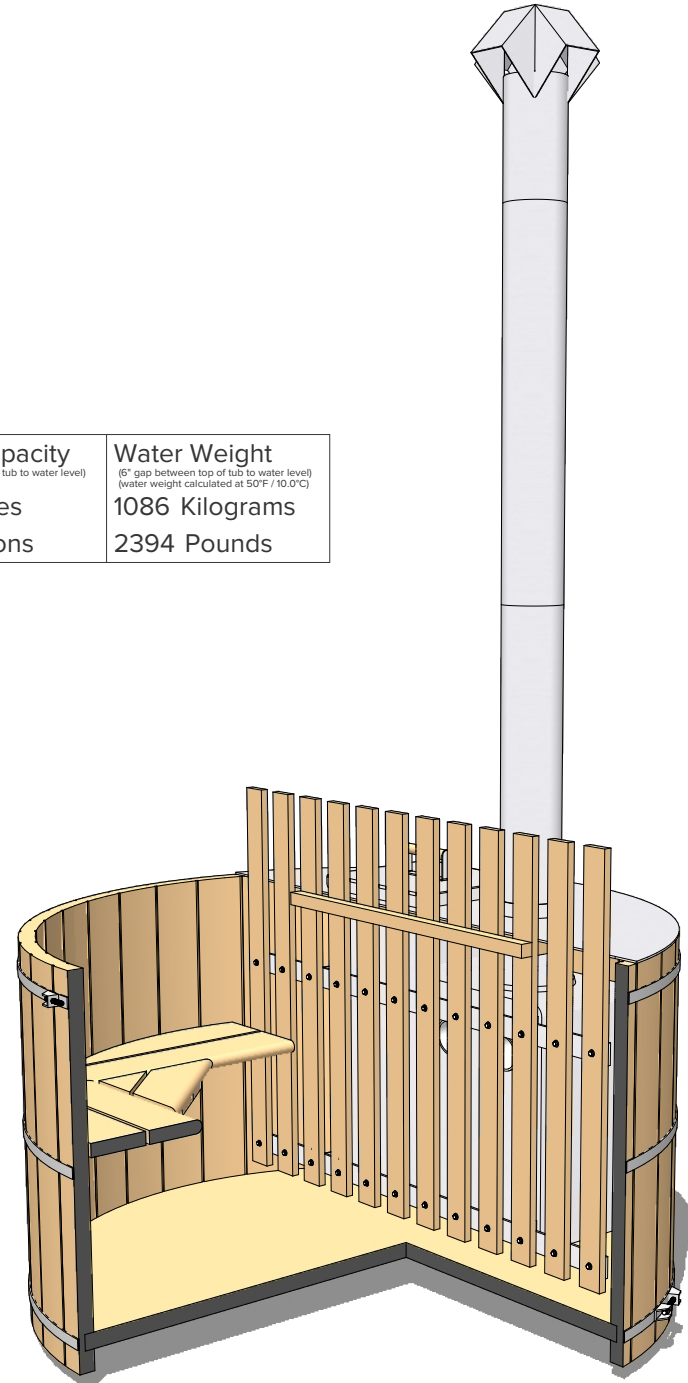
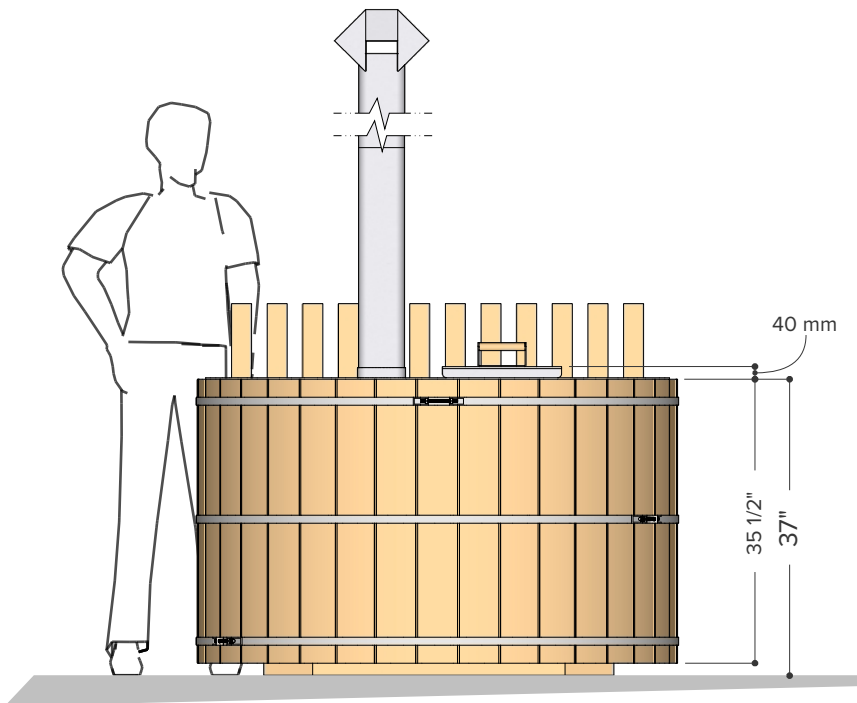

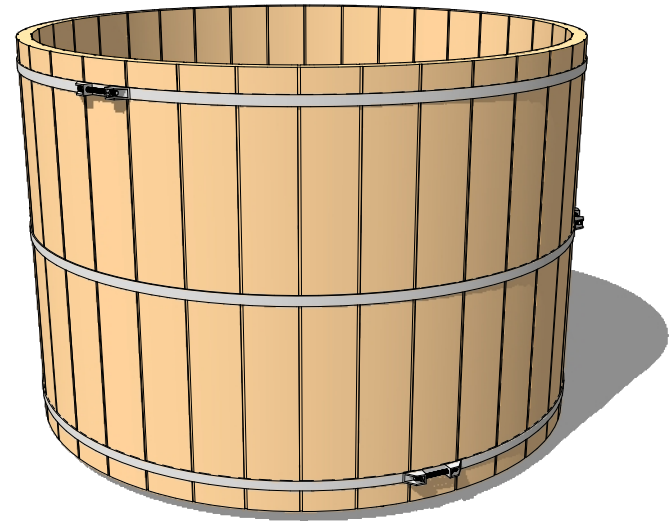
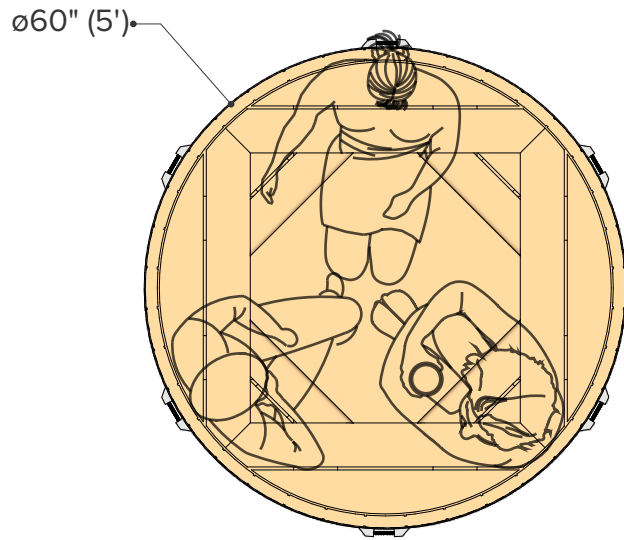

Occupancy	Water Capacity <small>(6" gap between top of tub to water level)</small>	Water Weight <small>(6" gap between top of tub to water level) (water weight calculated at 50°F / 10.0°C)</small>
Typical: 3	1337 Litres	1337 Kilograms
Max: 4	353 Gallons	2947 Pounds

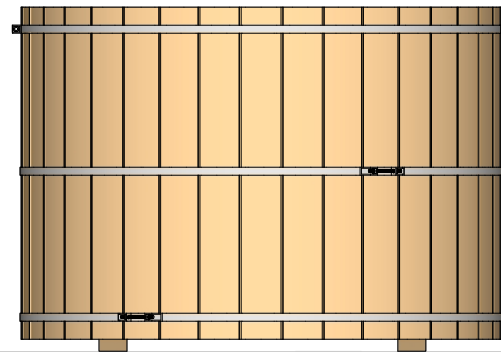
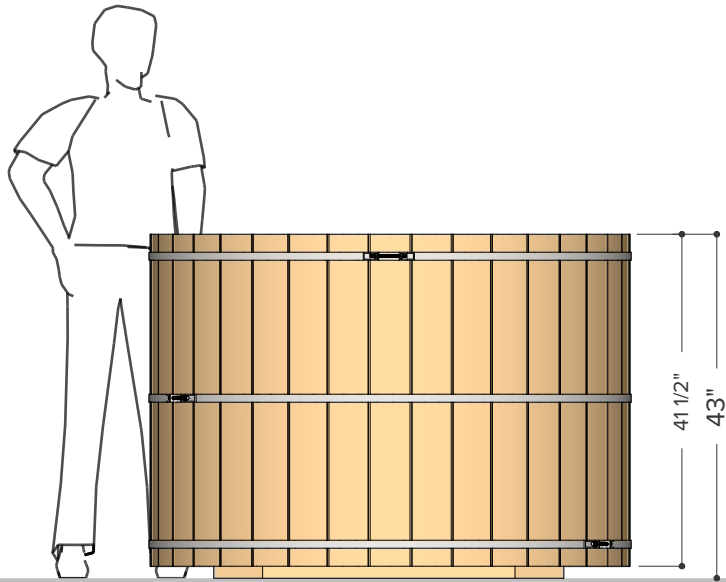

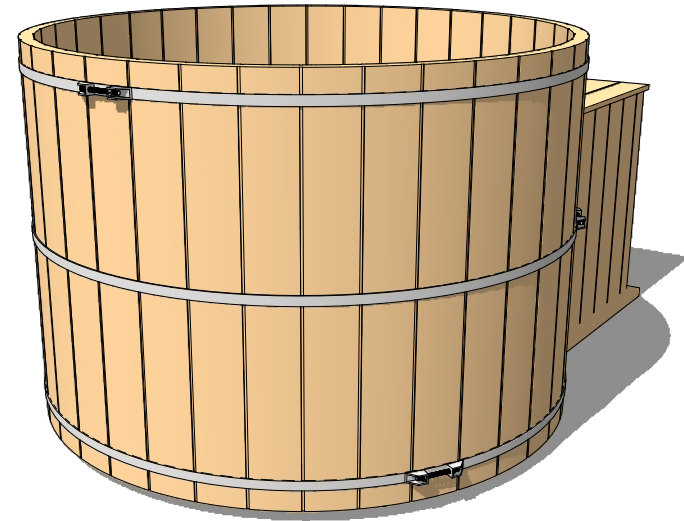
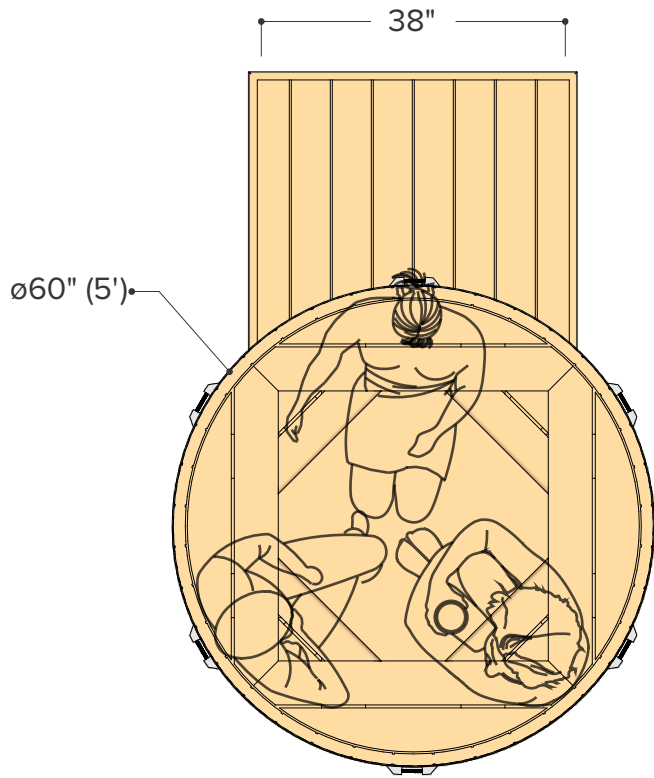

Occupancy	Water Capacity <small>(6" gap between top of tub to water level)</small>	Water Weight <small>(6" gap between top of tub to water level) (water weight calculated at 50°F / 10.0°C)</small>
Typical: 3	1337 Litres	1337 Kilograms
Max: 4	353 Gallons	2947 Pounds

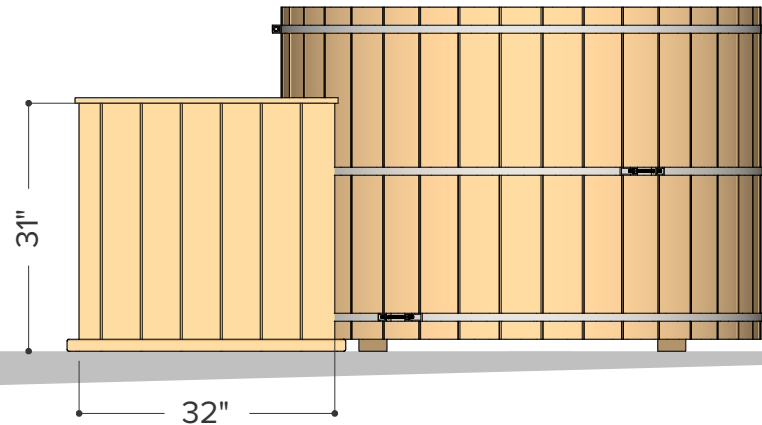
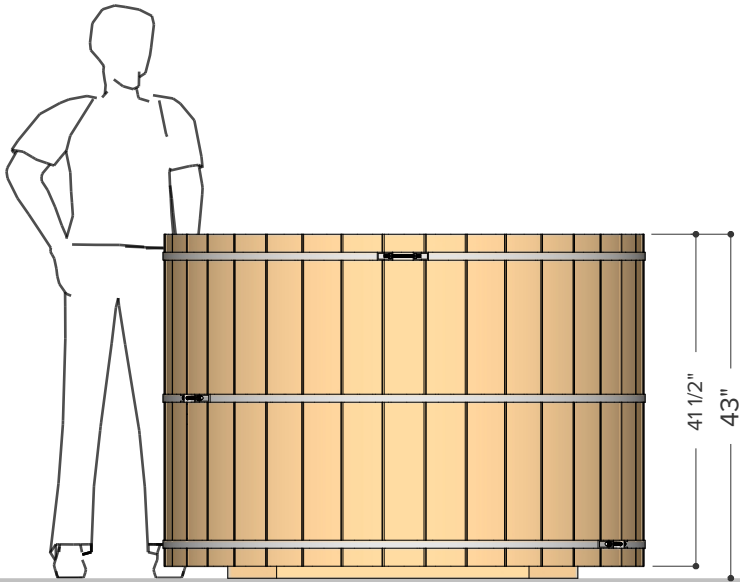

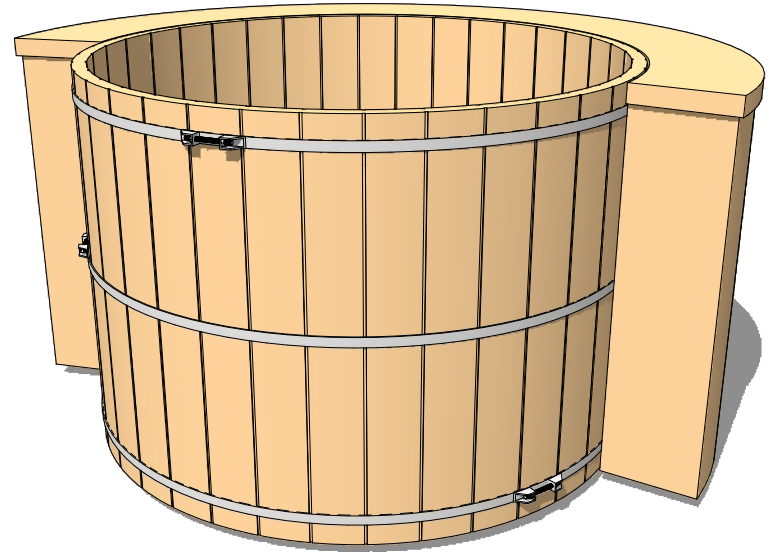
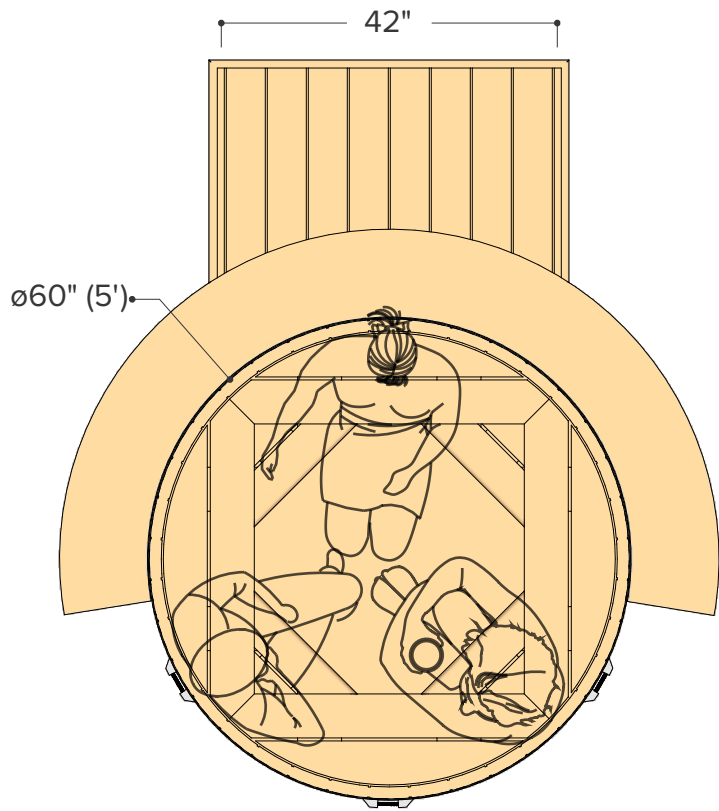

Occupancy	Water Capacity <small>(6" gap between top of tub to water level)</small>	Water Weight <small>(6" gap between top of tub to water level) (water weight calculated at 50°F / 10.0°C)</small>
Typical: 3	1337 Litres	1337 Kilograms
Max: 4	353 Gallons	2947 Pounds

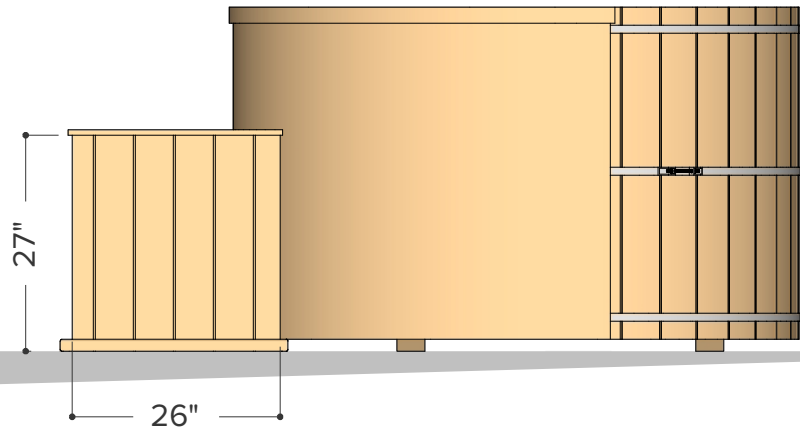
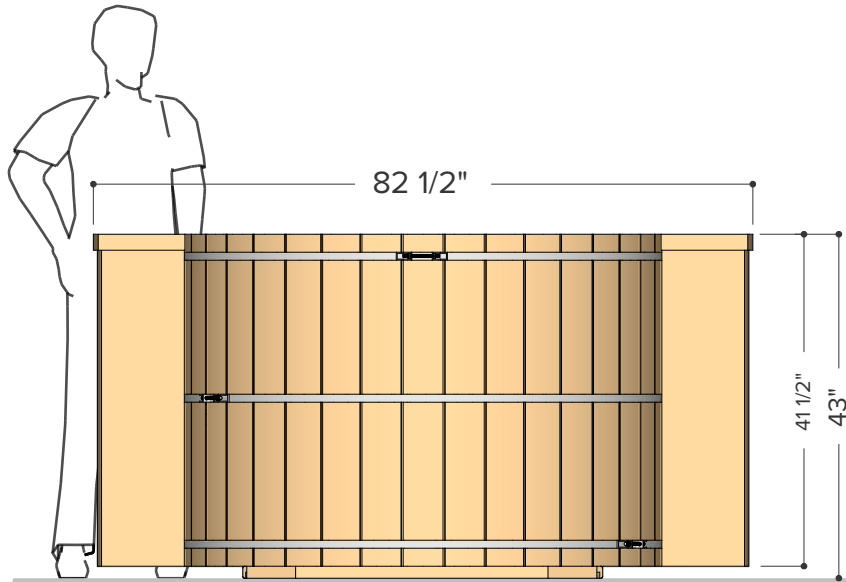

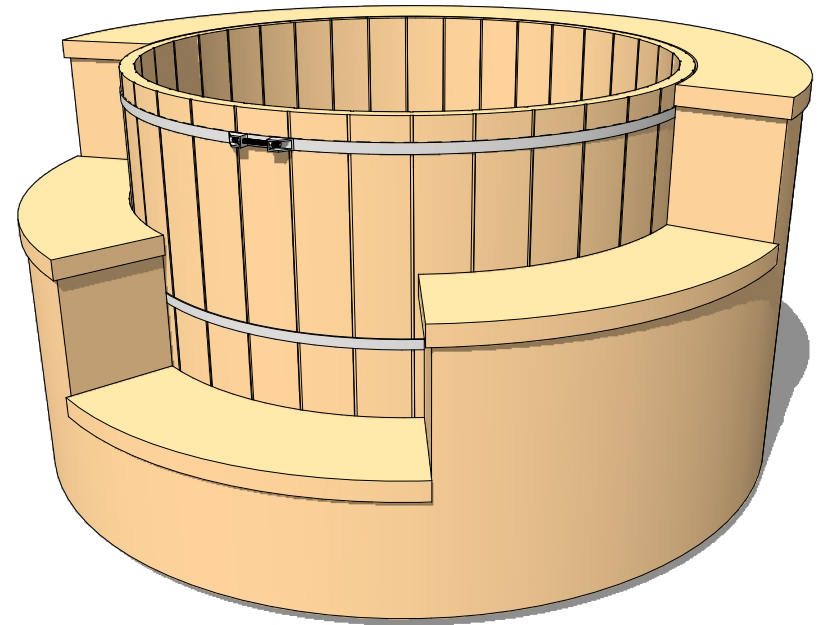
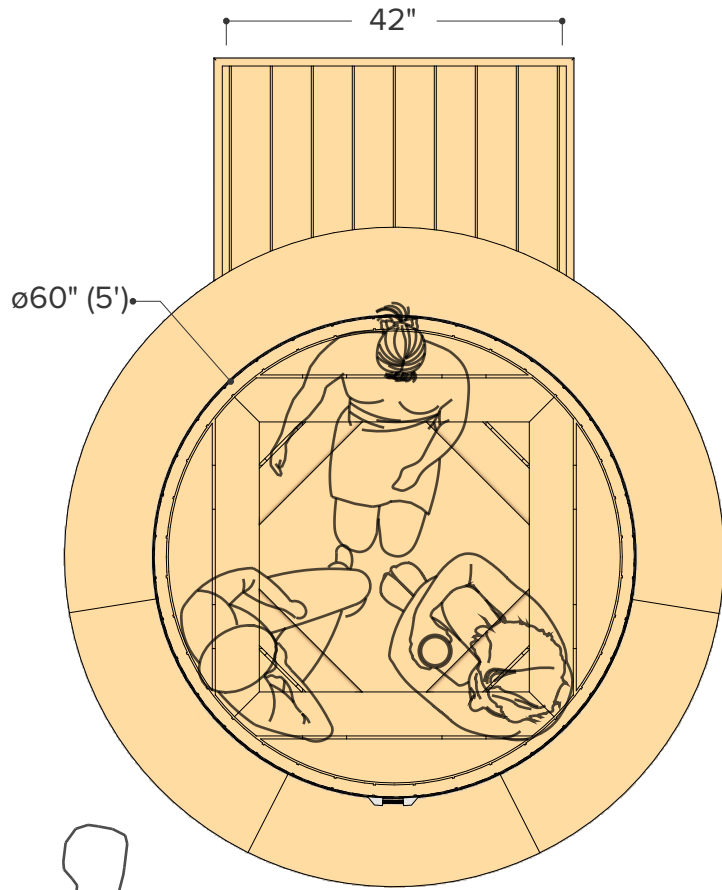

Occupancy	Water Capacity <small>(6" gap between top of tub to water level)</small>	Water Weight <small>(6" gap between top of tub to water level) (water weight calculated at 50°F / 10.0°C)</small>
Typical: 3	1337 Litres	1337 Kilograms
Max: 4	353 Gallons	2947 Pounds

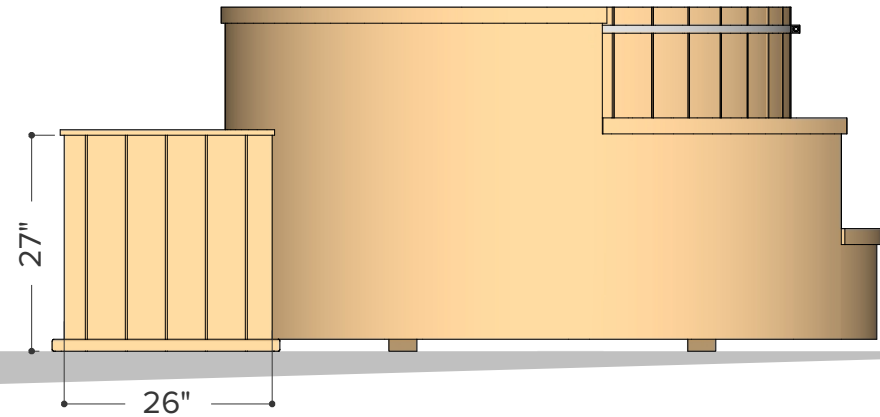
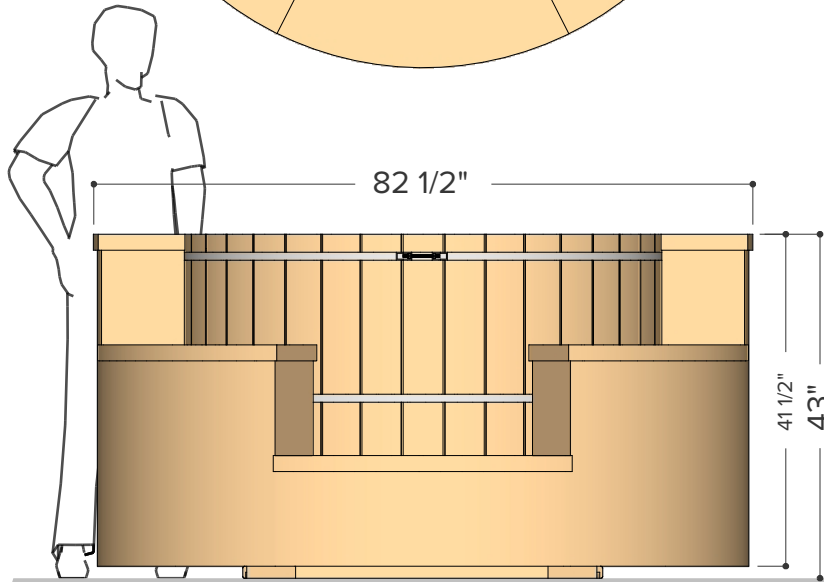

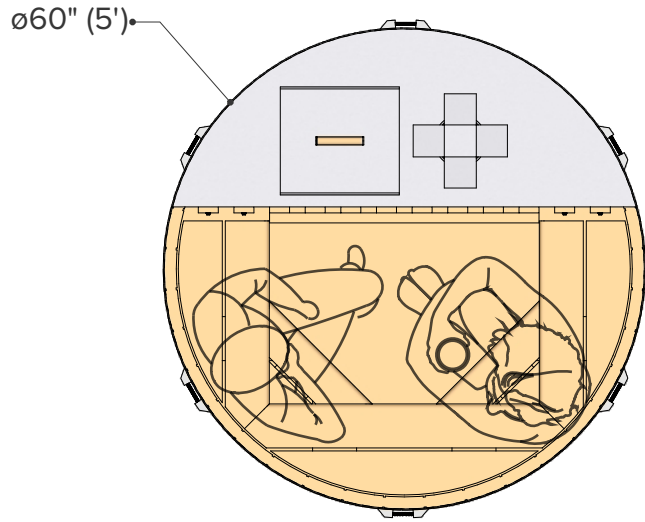

Occupancy	Water Capacity <small>(6" gap between top of tub to water level)</small>	Water Weight <small>(6" gap between top of tub to water level) (water weight calculated at 50°F / 10.0°C)</small>
Typical: 2	1337 Litres	1337 Kilograms
Max: 3	353 Gallons	2947 Pounds

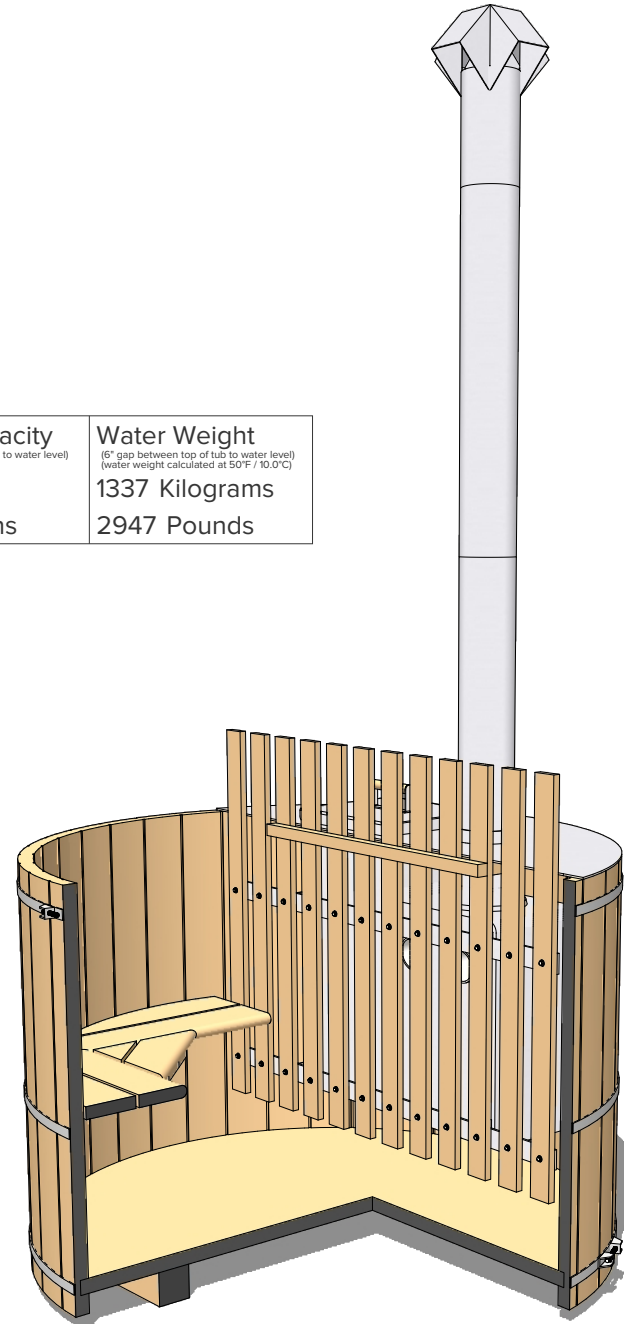
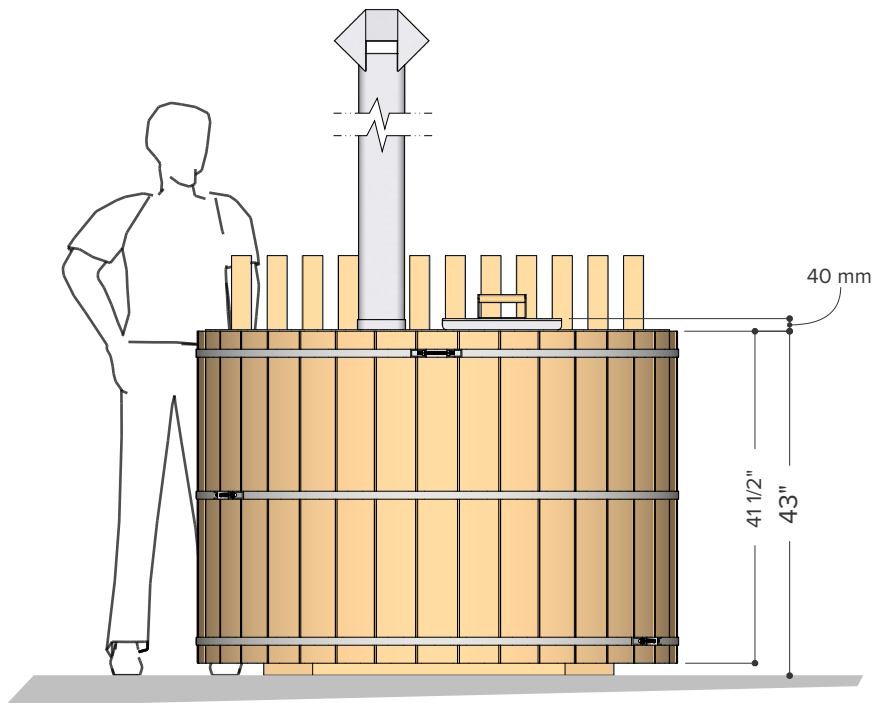

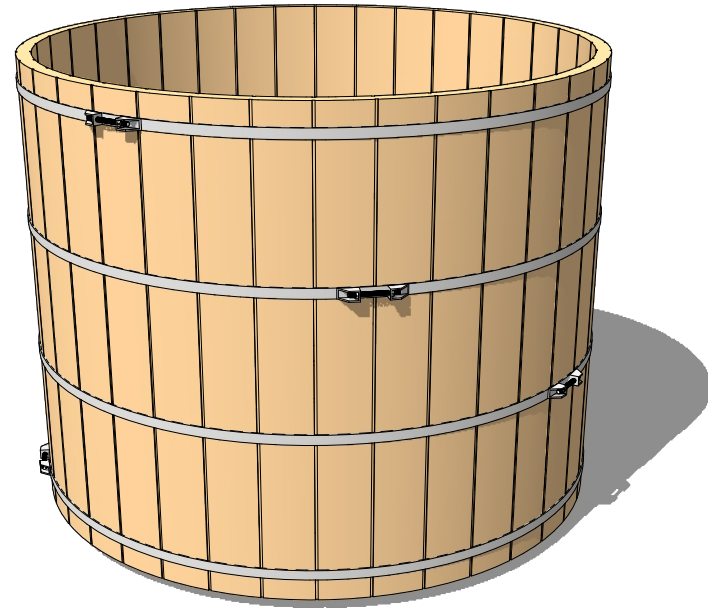
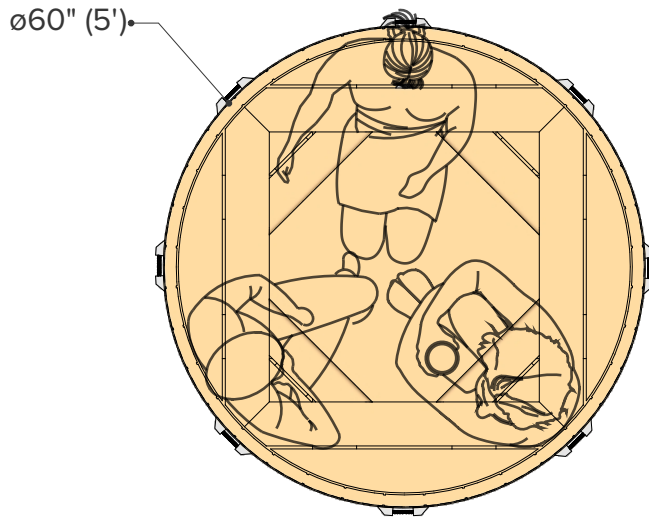

Occupancy	Water Capacity <small>(6" gap between top of tub to water level)</small>	Water Weight <small>(6" gap between top of tub to water level) (water weight calculated at 50°F / 10.0°C)</small>
Typical: 3	1588 Litres	1588 Kilograms
Max: 4	419 Gallons	3500 Pounds

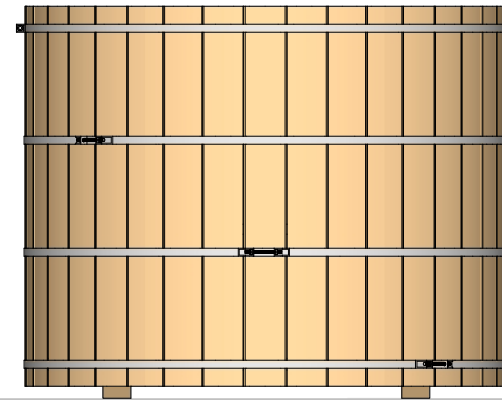
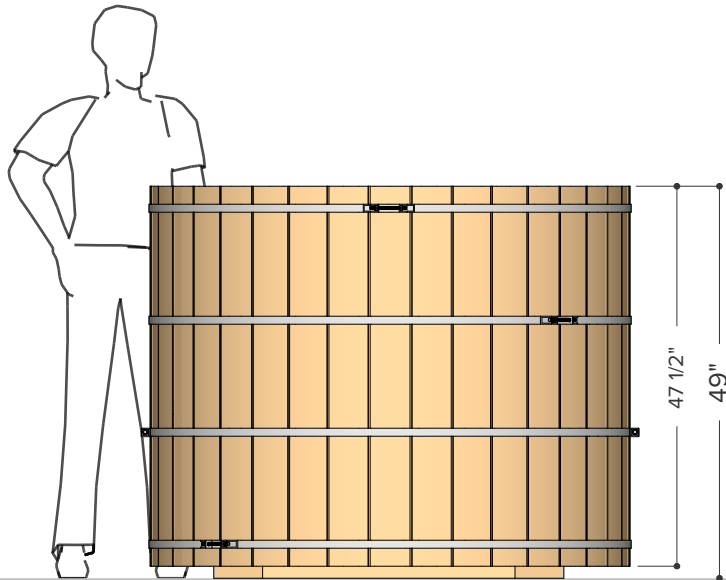

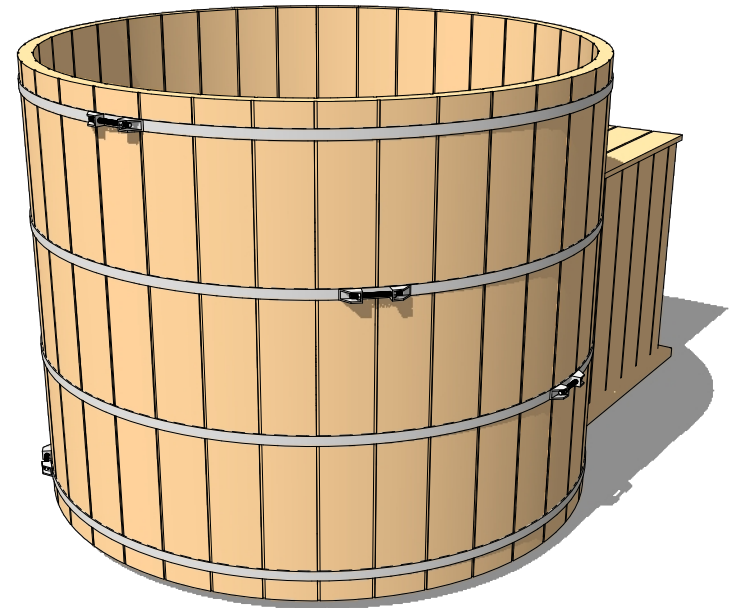
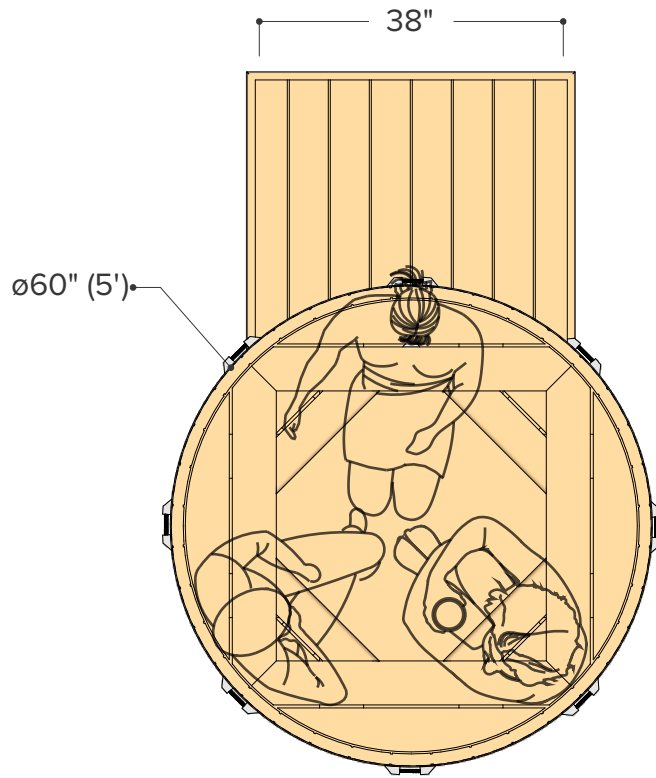

Occupancy	Water Capacity <small>(6" gap between top of tub to water level)</small>	Water Weight <small>(6" gap between top of tub to water level) (water weight calculated at 50°F / 10.0°C)</small>
Typical: 3	1588 Litres	1588 Kilograms
Max: 4	419 Gallons	3500 Pounds

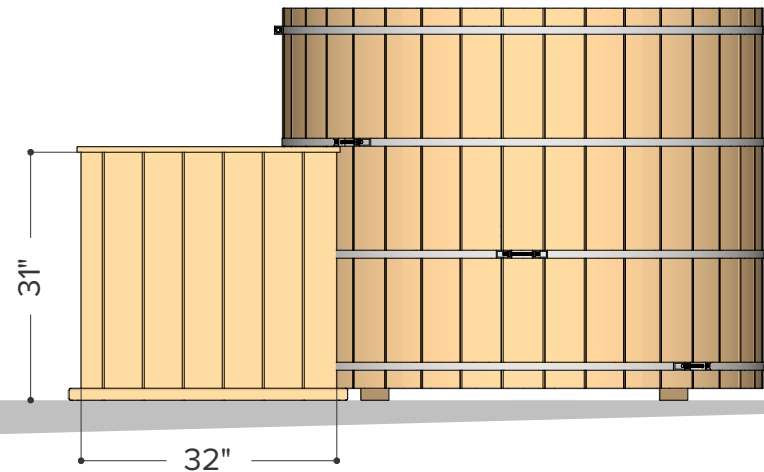
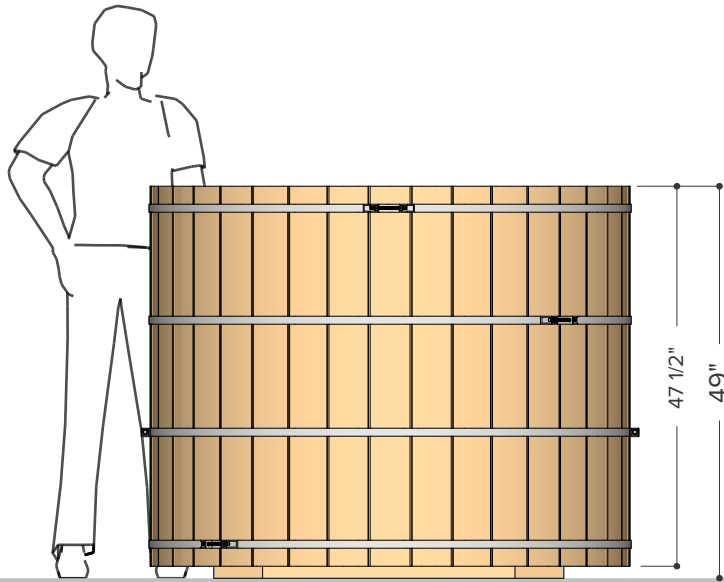

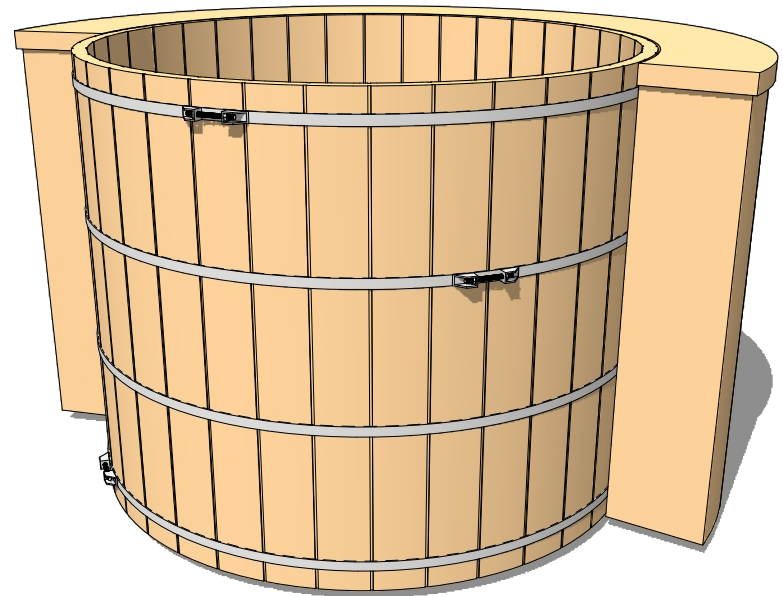
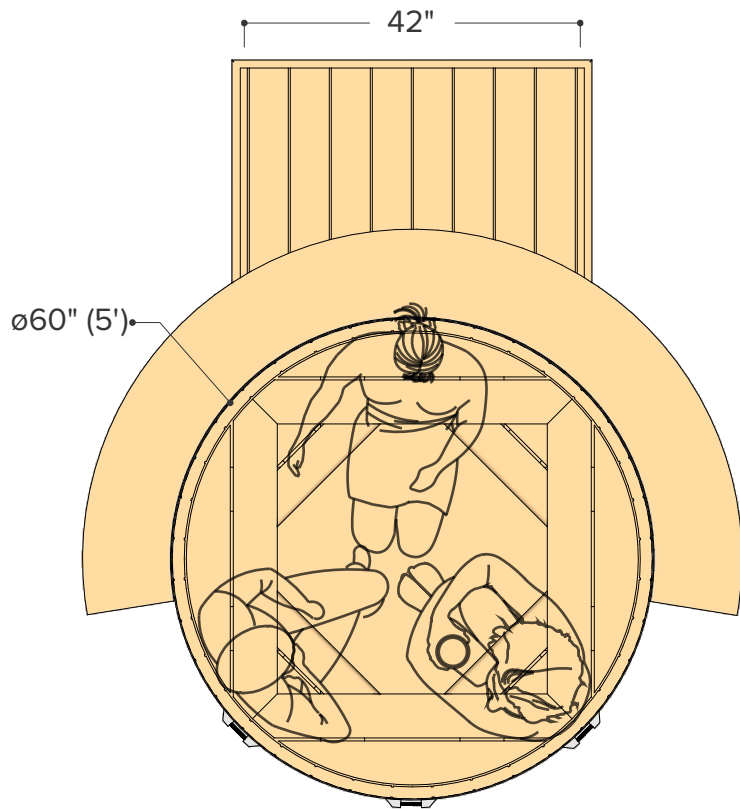

Occupancy	Water Capacity <small>(6" gap between top of tub to water level)</small>	Water Weight <small>(6" gap between top of tub to water level) (water weight calculated at 50°F / 10.0°C)</small>
Typical: 3	1588 Litres	1588 Kilograms
Max: 4	419 Gallons	3500 Pounds

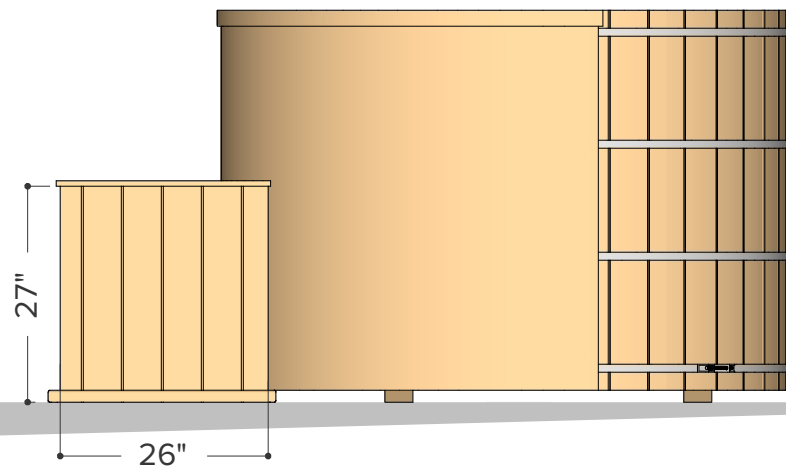
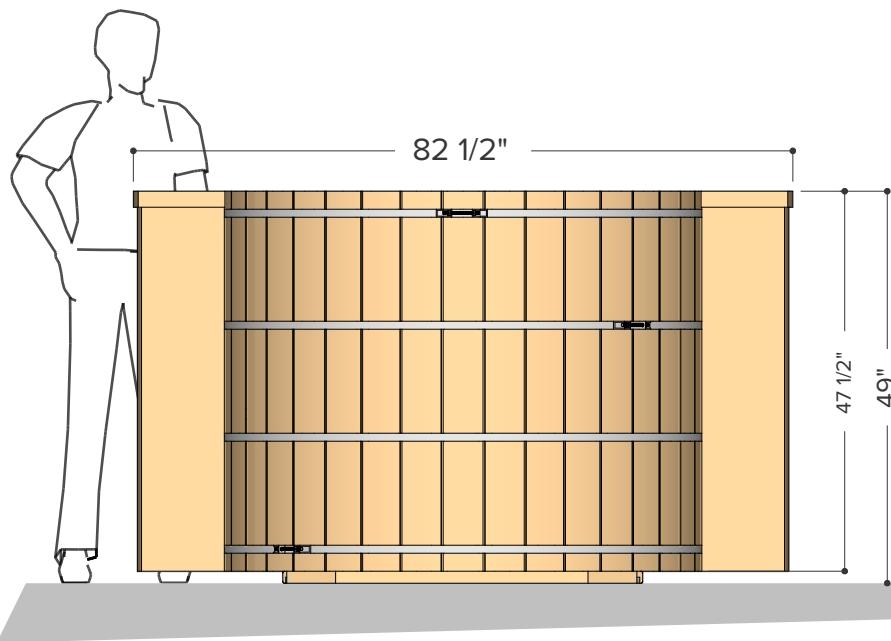

FOREST
- COOPERAGE -

ø5' x 4' Tub &
Multi Skirting Kit

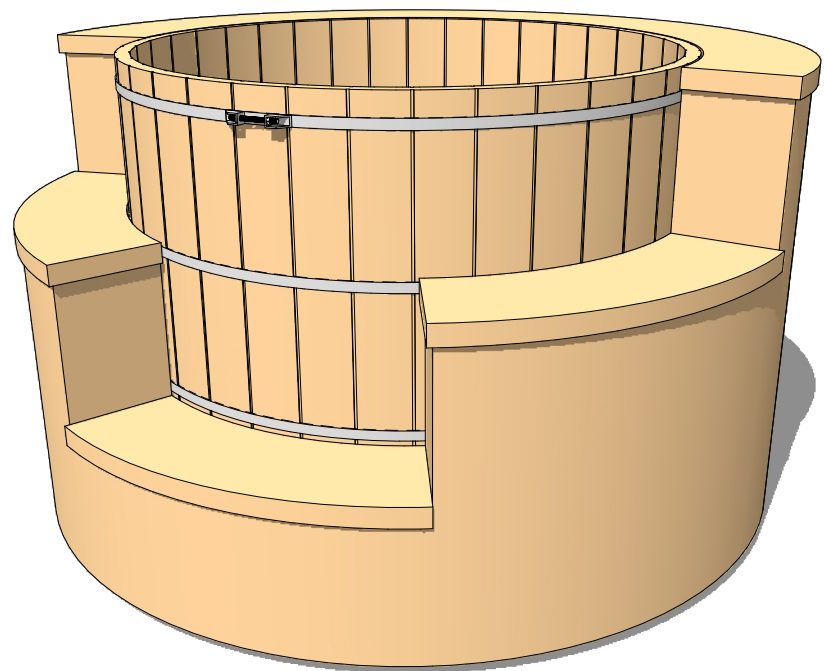
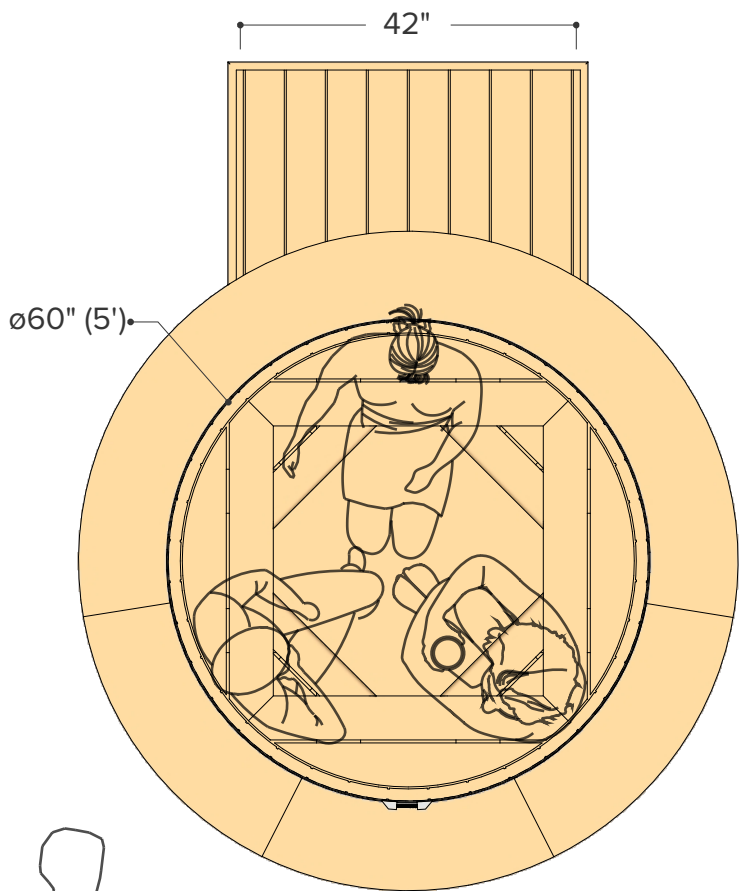

Occupancy	Water Capacity <small>(6" gap between top of tub to water level)</small>	Water Weight <small>(6" gap between top of tub to water level) (water weight calculated at 50°F / 10.0°C)</small>
Typical: 3	1588 Litres	1588 Kilograms
Max: 4	419 Gallons	3500 Pounds

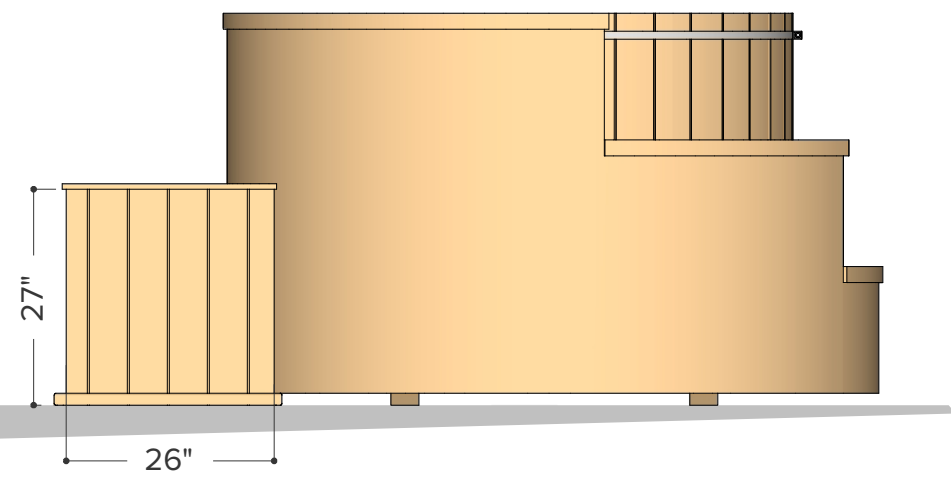
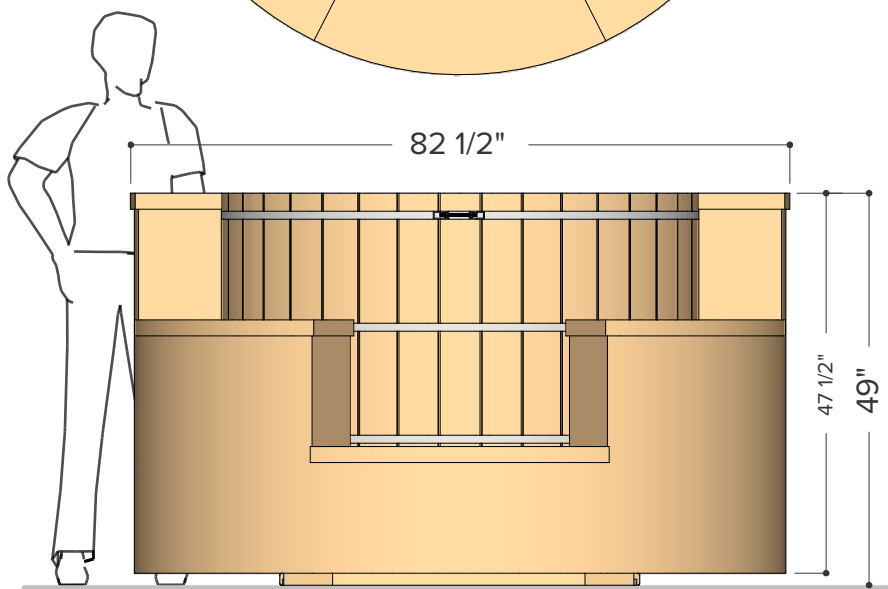

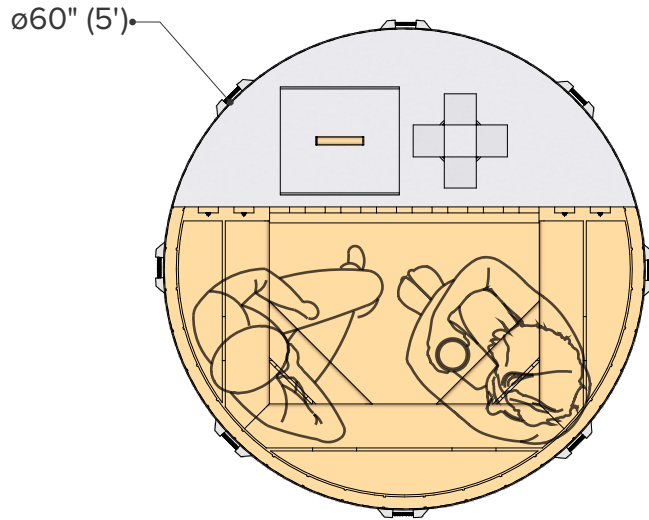

Occupancy	Water Capacity <small>(6" gap between top of tub to water level)</small>	Water Weight <small>(6" gap between top of tub to water level) (water weight calculated at 50°F / 10.0°C)</small>
Typical: 2	1588 Litres	1588 Kilograms
Max: 3	419 Gallons	3500 Pounds

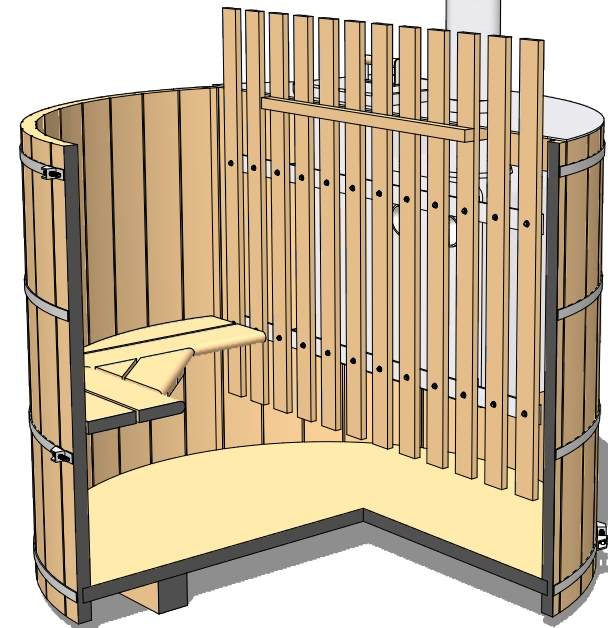
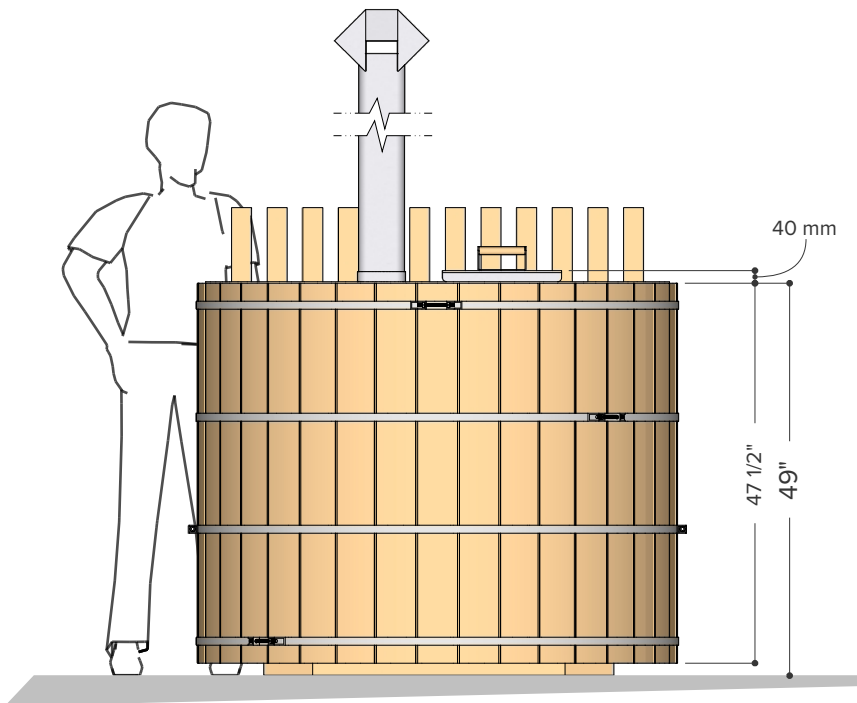
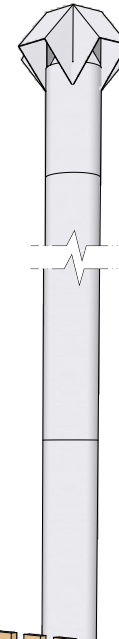

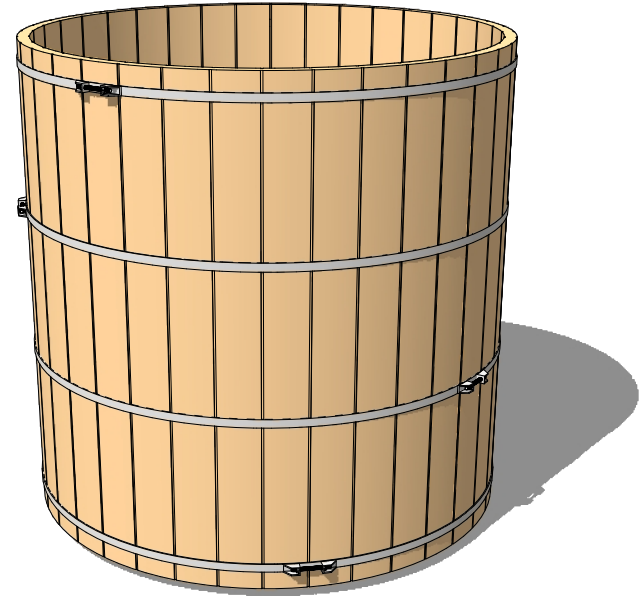
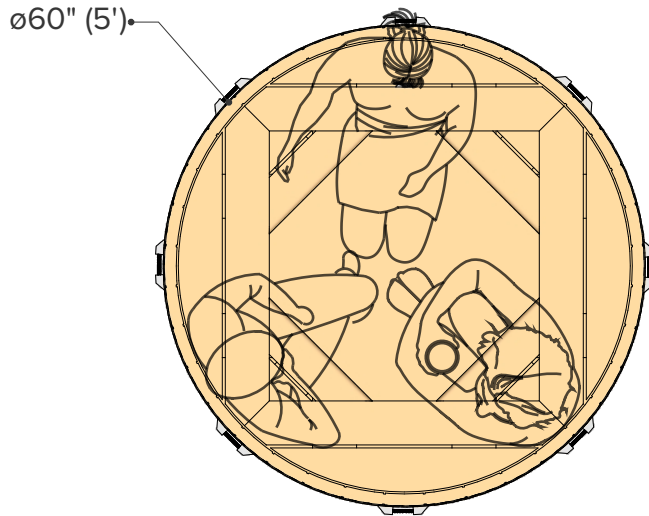

Occupancy	Water Capacity <small>(6" gap between top of tub to water level)</small>	Water Weight <small>(6" gap between top of tub to water level) (water weight calculated at 50°F / 10.0°C)</small>
Typical: 3	2089 Litres	2089 Kilograms
Max: 4	552 Gallons	4604 Pounds

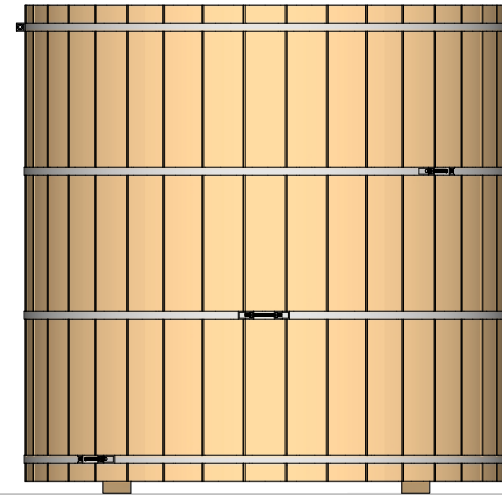
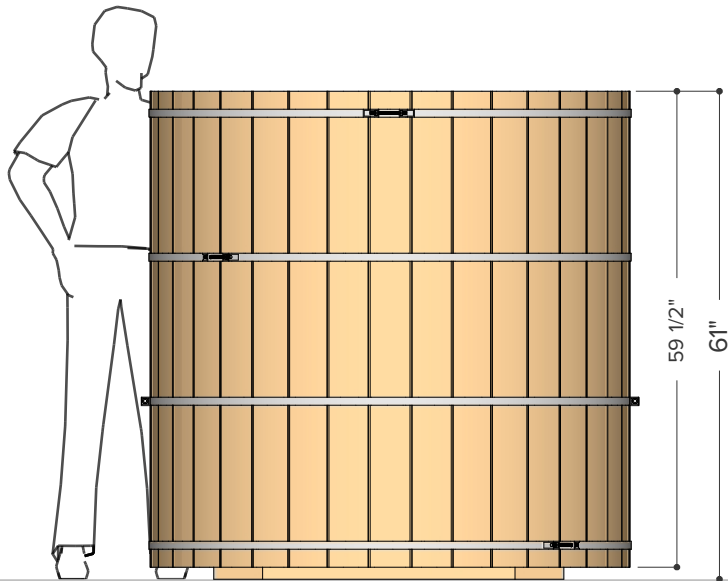

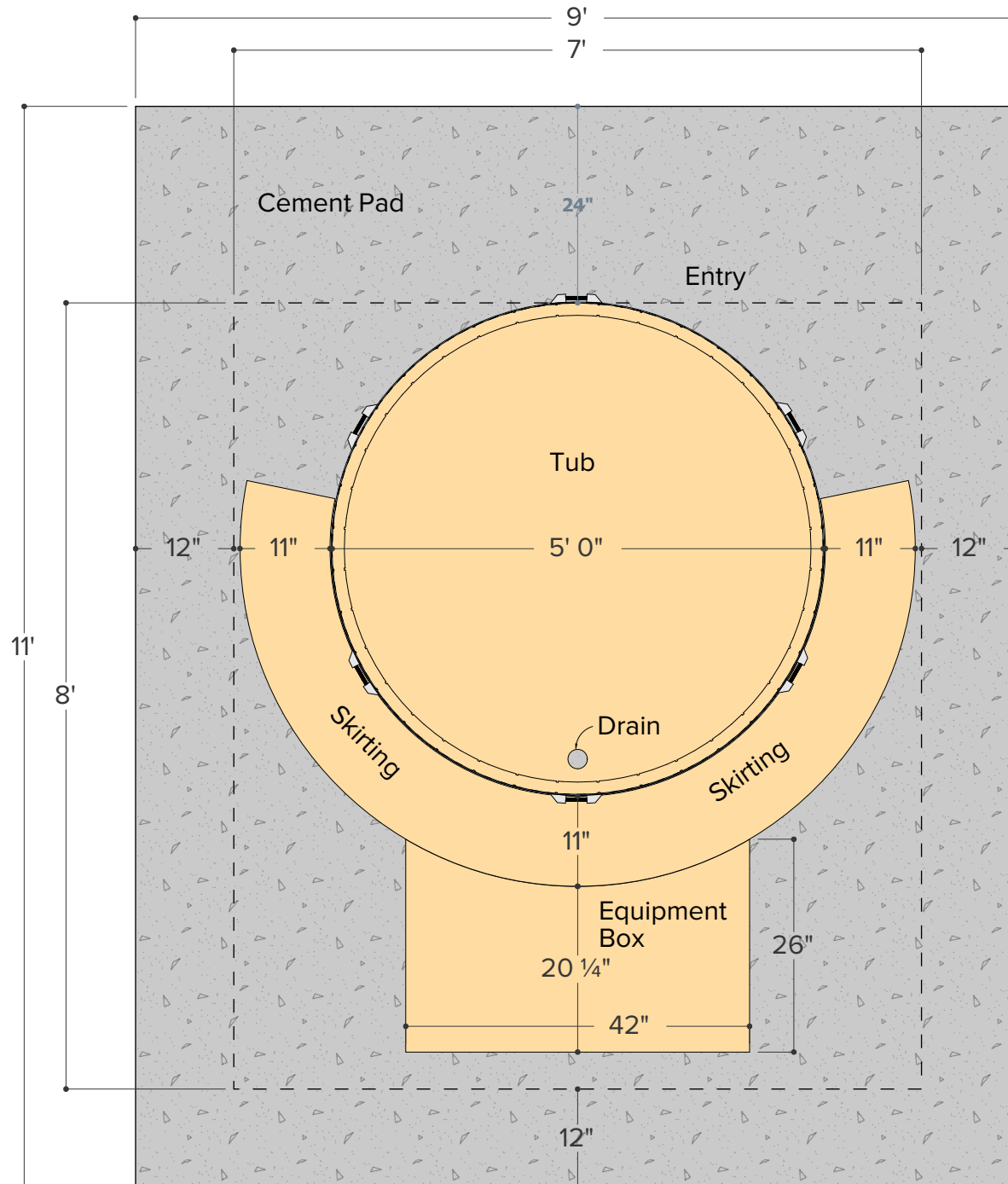

Give at least 6" Clearance from edge of pad to all parts of the tub

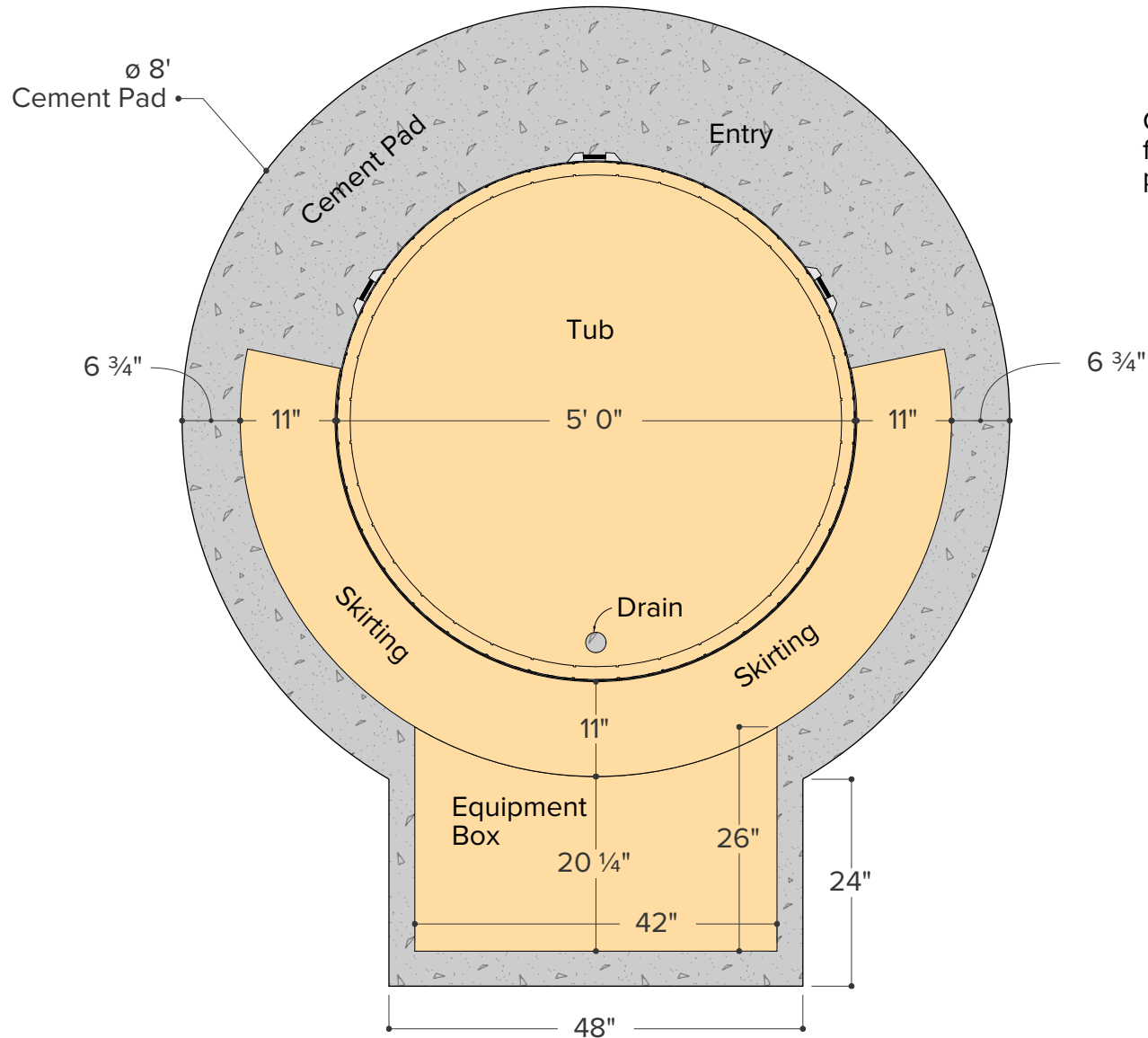

Give at least 6" Clearance
from edge of pad to all
parts of the tub